

Woodturning 150 Student Handout

Discussion

The objectives for this course is to improve the participant's skill and confidence with spindle turning tools and techniques. To accomplish these goals activities have been selected to both practice existing skills and introduce new spindle turning techniques. Activities and project have been selected to accomplish these goals while have fun in the process.

At any time, other activities or skills may be introduced to meet student's specific objectives.

Some goals are:

- Introduce new techniques for using existing spindle and other tools
- Expand skill in turning beads
- Increase skill and confidence in the use of the skew chisel

Planned activities include:

Week 1 – Review and elaboration on turning beads with the shallow-fluted gouge (bead & cove stick)

Week 2 – Practice in the use of the skew chisel (spin tops)

Week 3 – Multi-axis turning of “ghosts” (three-axis letter opener)

Week 4 – Goblets

Week 5 – Turning spheres by multiple methods

Week 6 – Turning delicate finials

Activity 1 - Turning beads

Activity I - Finger practice

- At the lathe with it switched off, point your index finger across the tool rest.
- With your index finger pointed straight ahead, rotate your wrist while maintaining the finger position – practice this activity several times.
- Next while doing the rotation (as above) move your wrist toward the tailstock (or headstock if left handed) – practice this several times until you can do both the rotation of the hand and the swinging of the wrist at the same time.
- While performing the last step, insert the shallow fluted gouge under the index finger and continue the activity.

These are the exact motion necessary to turn a bead successfully. Now do the same activity with the other – less dominant- hand.

Activity I – Turning beads

- Mount a practice blank and turn the blank round with the spindle roughing gouge.
- Plane the blank smooth with your skew chisel then add parting cuts about one inch apart with your parting tool.
- Mark the center of each one-inch section with a pencil.
- Begin turning a bead by resting the shallow fluted gouge on the spindle surface with the flute of the tool facing slightly to the right.
- Raise the handle until shavings begin to appear then roll the tool over to the right, shaving off the right corner.
- Repeat the action facing the tool to the right and shaving off the right corner.
- Continue cutting with the tool moved closer to the pencil mark and a greater radius is cut on both left and right sides.
- As the bead becomes more pronounced the tool is rolled further each way so that the cutting edge can stay in contact with the wood surface which is no longer horizontal but is becoming more vertical.
- As the bead takes shape, the handle of the gouge must also be moved laterally to allow the cutting edge to stay engaged with the wood surface which is now almost vertical.
- Next follow the same procedure for the left side of the beads.
- Complete as many beads as are possible on the practice stock mounted.

Activity 2 - Spin Tops

Objectives

- Create a quick, fun project.
- Practice using the skew chisel to develop personal skill.



Materials required

- Hardwood 2-3" square x 4" long.

Tools & Equipment required

- Live center and spur drive.
- Four- jaw scroll chuck.
- Spindle roughing gouge.
- Parting tool.
- Skew chisel.
- Color markers for decoration.
- Wax for finish.

Discussion

This activity can be completed using only the skew chisel for all steps.

As the top is turned it can be decorated with color, burn wires, or...? Be sure to part off the point area carefully to get a clean cut that will allow the top to spin smoothly. Keeping the spin point low in the design will allow for more stable and longer spins. Experiment! There will be a contest at the end of this activity!

Activity

- Set the lathe speed to approximately 1800 RPM and mount the wood between centers and turn it round with the spindle roughing gouge.
- Add a tenon to match your chuck and remount the blank in the four-jaw scroll chuck. Re-true the blank if necessary.

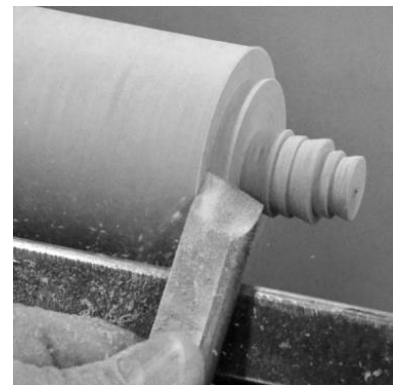

- Using the skew chisel make several “peel cuts” to reduce the diameter of the end to slightly larger than required to finger spin the top. Keep the long point of the skew chisel toward the headstock end during this cut. Take several small cuts reducing the shaft diameter in steps.
- Using the long point end of the skew chisel make planing cuts to smooth out the finger spinning end.



- Still using the skew chisel make a “V” cut to clean up the upper surface of the top’s face. Allow a small clearance angle between the tool and the vertical surface being cut.
- Sand and complete the upper surfaces adding any decoration or colors to make the top more interesting.
- Starting about ½” to the left of the desired bottom of the top, make a “V” cut with your skew chisel. Enlarge the “V” cut from both the left and right sides deepening and widening the cut. When the diameter is very small, hold the handle of the top in one hand and continue the “V” cut until the base is parted off.

Remember to keep a small clearance angle between the tool and the wood being cut. Focus on making clean, continuous cuts from both sides.



ACTIVITY 3 - Three-Axis Letter Opener

Objectives

- To practice working on multiple axis on one project

Materials require

- 1 ½ x 1 ½ x 11 straight grained hardwood



Tools required

- Drive center & live Center
- Turning tools for roughing and fine turning
- Sand paper and finish

Activity

Prepare the blank

- Carefully mark the center of the blank on each end
- Draw a line through the center point perpendicular to the grain
- Mark two off set points on this perpendicular line 3/8" on either side of the true center on both ends. Center punch these marks; this will be the blade end
- Mount and seat the blank on all center points before beginning the turning.

Turning the letter opener to shape

- Mount the blank on the true center and turn it to approximately 1" diameter cylinder while leaving a 1" square at each end
- From the 1" square, mark off 4" in the headstock end: this will be your handle
- The remaining 5" on the tailstock end will be the blade
- Turn the handle portion (nearest the drive center) to its final shape suitable to fit your hand
- Turn a 5/8" cove between the handle and the blade
- Turn the blade portion to a taper leaving at least ¼" at the tip of the blade

Marking the center of the blade

- Rotate the blank so that the offset punched holes are at 3 o'clock and 9 o'clock (horizontal)
- On the top dead center of the blade portion, draw a line from the tip to the handle
- Rotate the blank 180 degree and draw a second line on the opposite side

Shaping the blade

- Move the blank's tip to one of its offset centers and begin turning the face of the blade DO NOT TOUCH THE HANDLE PORTION
- Take a few light cuts on the ghost image (lighting adjustments may improve your view of the "ghost")
- Transfer to the opposite offset center and begin turning from this face by taking a few light cuts
- Continue shaping the blade by alternating cuts between offset center and approaching the penciled lie evenly from both sides.

The pencil lines will guide you to cutting evenly on both side of the blade – work toward evenness.



Finishing touches

- Once you have formed the blade, return the blank to the true centers and sand the blade and the handle with the lathe power off
- Finish the turning process by reducing the diameter at the handle end to 1/8" and re-sand the handle end if necessary – keeping the square end in tact
- Cut the excess waste from the project at the band saw and hand sand the cut areas forming the tip of the blade as you go
- Add an oil finish

Activity 4 – Goblet

Special Supplies

- Wood blank 3" x 3" x 8".
- Tennis ball (well used).

Turning a goblet introduces the new turner to a third turning orientation, turning end grain, which requires cutting into the end of the wood fibers with an edge tool or a scraper. Goblet turning is a combination of turning a spindle and turning a small end grain bowl.

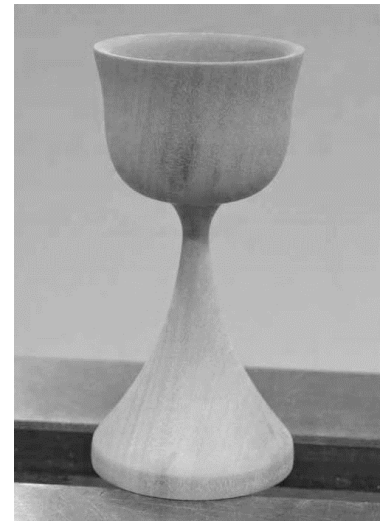

Note that in end grain turning (the hollowing of the “bowl” portion) downhill to the grain is from the center of the wood outward. To work from the center outward it is easier to drill a pilot hole large enough to insert the shallow fluted gouge. This can be done with standard drill bits or with a shallow fluted gouge as in this example.

Since most goblets have slim stems that will not support turning work on the cup area, the turning must be completed from the top of the goblet toward the base. The longer the stem or the thinner it is the more difficult the project becomes.

Activity

- Prepare the stock by mounting between centers, turning it round and adding a tenon for your scroll chuck. Remount the blank in your four-jaw scroll chuck and bring up the tailstock for additional support. Retrue the blank if it is necessary.
- Shape the exterior of the cup portion (Photo 2) with a shallow fluted gouge at the tailstock end of the project wood. Do not reduce the stem diameter now. We need it for support until after the interior of the cup is hollowed out. Remove the tailstock from the lathe.



- While you can use a Jacobs Chuck and drill bit, try using the shallow fluted gouge technique by adjusting your tool rest to set the cutting edge of the gouge to be exactly at the center of the blank.

- With the lathe running at a moderate speed, approximately 1200 RPM, press the gouge straight into the center keeping the handle level. Remove waste and reintroduce the gouge.

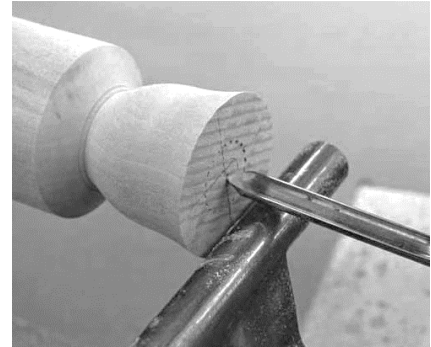
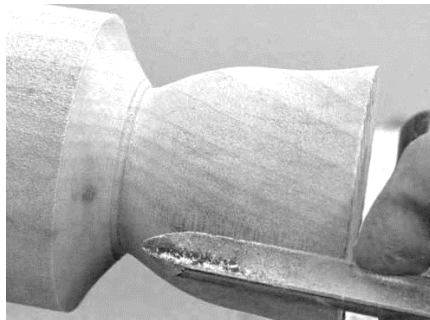

- Shape the inside of the cup by opening the interior from the center outward with the gouge held at approximately 45-degrees counter clockwise to rotation.
- Before starting increase the lathe speed to approximately 1800 RPM as you will be working at the center where wood moves past the cutting edge at a lower inches-per-minute surface speed.

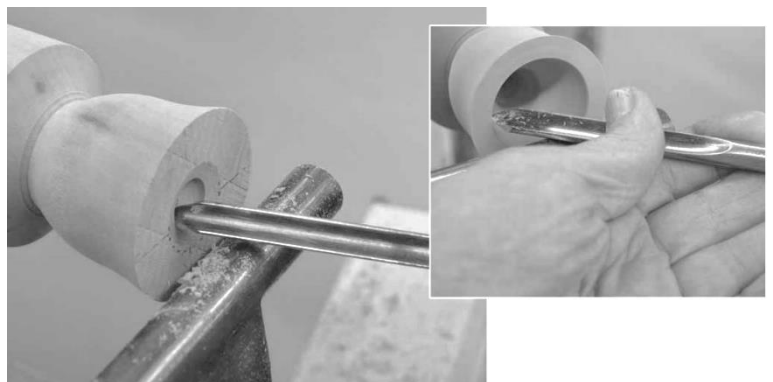

- Hold the rotated tool in your right hand, pinch the shaft at the tool rest with the left hand and cut by moving the right hand horizontally away from the lathe to the rear. To go deeper slowly advance the tool remembering to swing the handle backward for each cut. Focus on keeping the tool at the 45-degree orientation; too vertical and it will catch, too horizontal it will cut poorly.
- Complete the cup interior by sanding through all the desired grits as you will not be able to work in this area later. Measure the exact depth turned and transfer that measurement to the exterior of the blank for use in the next step.

- Insert a tennis ball into the completed goblet cup and hold it in place with the tailstock live center for support. Turn the exterior of the cup observing the marked depth. Turn the stem by reducing it carefully from the tailstock end toward the headstock still using the shallow fluted gouge.

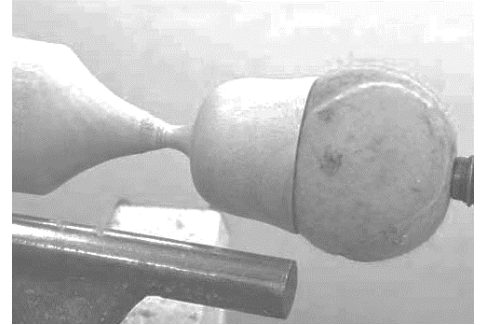

- Shape the base last (Photo 8). Its size is generally about the same diameter or slightly larger than the cup portion. When completed, sand the exterior and part off

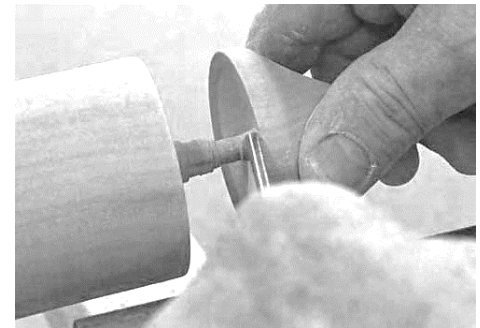

Activity 5 – Turning Spheres

Requirements

- a. Calipers, ruler, dividers, pencil, compass, cutoff saw
- b. Cup chuck, live center with cone, spur drive
- c. Gouges, skews, parting tool
- d. Good, bright light

Method 1 – Free hand turning

- Mount stock between centers and turn it round
- Measure the diameter with calipers and transfer that diameter to long axis with pencil
- Reduce stock beyond pencil marks
- Turn into sphere by eye checking the progress with a provided template
- Cut off the ends beyond pencil marks
- Mount cup center on headstock and tailstock
- Rotate sphere 90° and remount it in the cup chuck
- Turn away any shadows

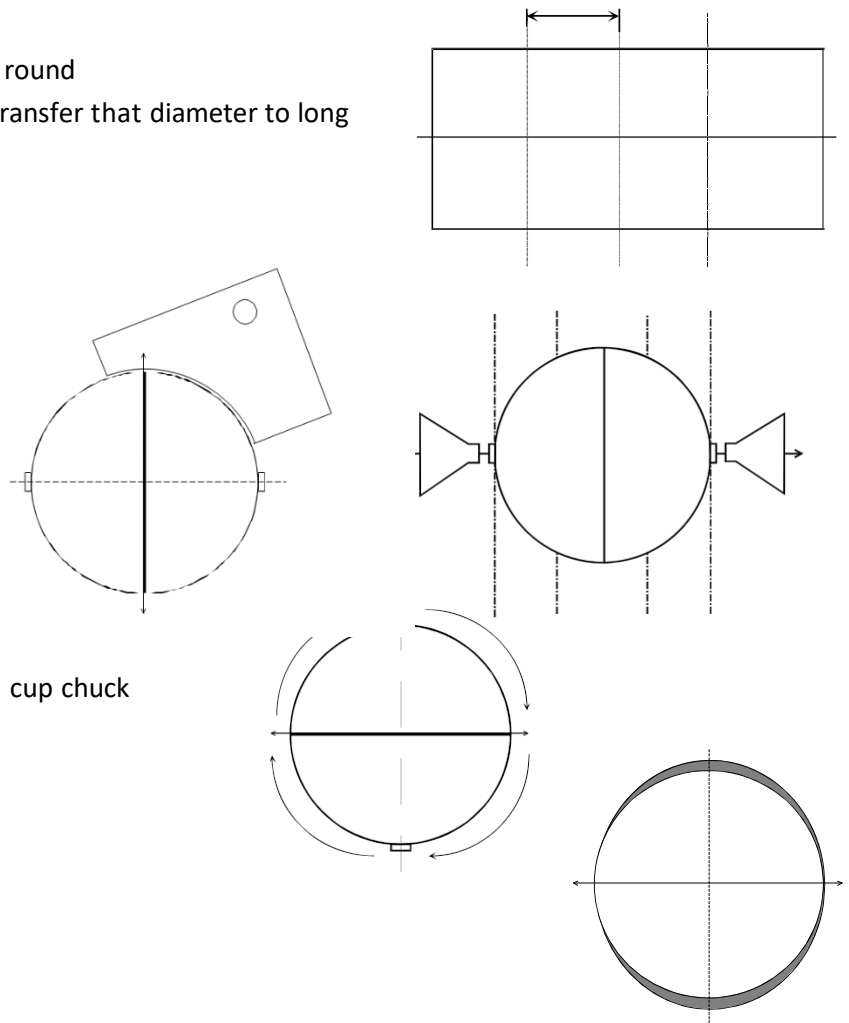

Method 2 - Octagon method

- a. Turn the blank to round with a 2-inch diameter
- b. Mark as in the first process marking the center and the two ends
- c. Multiply the radius by .414 and transfer this measurement to either side of the center line (radius is 1" x .414 = .4 inches)

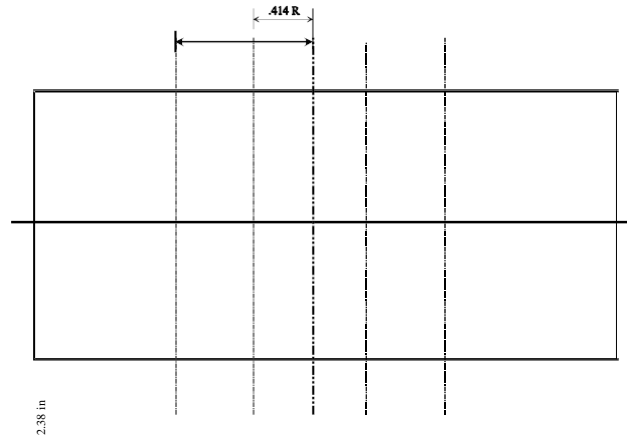

- c. Reduce the marked ends to twice the above measurement (set your calipers to the outside width of the two marked added above)

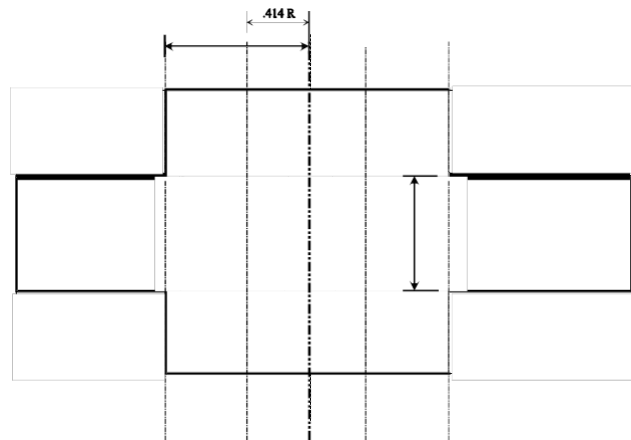

- d. Turn straight diagonal from the added marks to the reduce end diameters

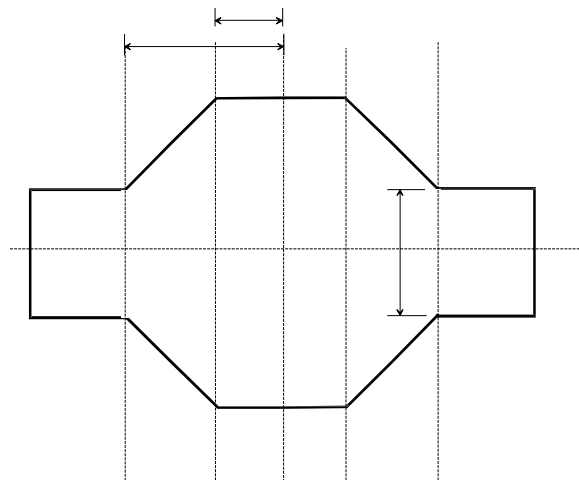

e. Reduce the tendons at both end

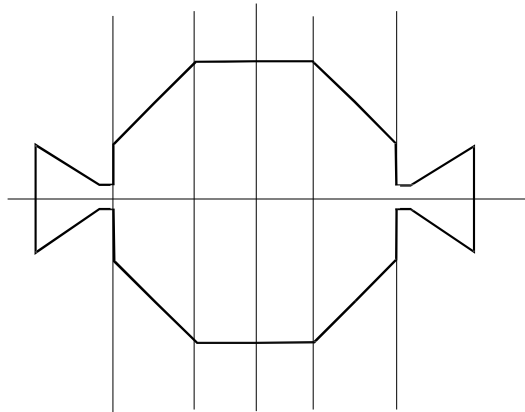

f. Place a center line on all flats

g. Turn the sphere by rounding the corners and leaving all lines

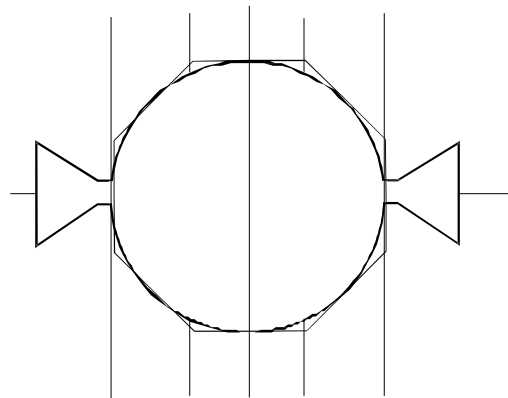

h. Rotate sphere 90°, remount in cup chuck and turn away any shadows

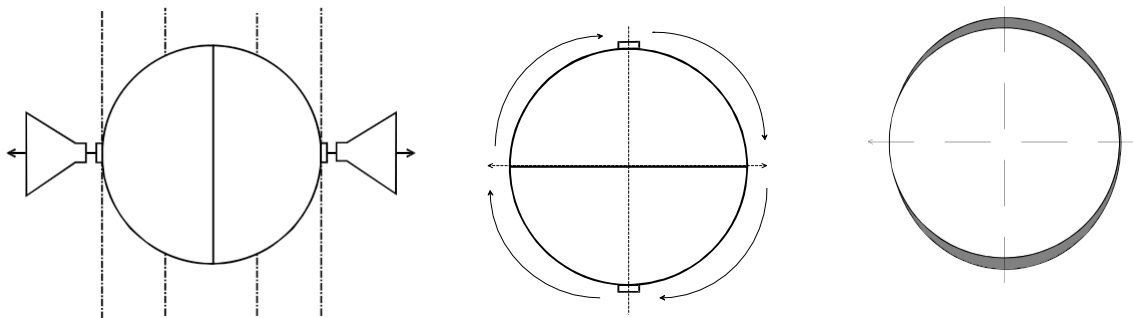

Activity 6 - Creating the finials

Objectives

- Create small taper turning with delicate detail
- Practice using the skew chisel and detail spindle gouge

Materials required

- Straight-grained hardwood 1 ½ x 1 ½ x 6 inches

Tools required

- Roughing gouge
- Detail spindle gouge
- Skew chisel
- Four-jaw scroll chuck
- Live center

Discussion

These finials can be produced for a variety of applications such as Christmas ornaments, box lids, etc.

The longer the finial the more the turners is required to support the turnings as they proceed from the tailstock end towards the headstock.

Activity

- Mount the finial blank into the base portion of the four-jaw scroll chuck and support the opposite end with the tailstock and live center.
- Increase the lathe speed to a minimum of 1,500 RPM.
- With your skew chisel or shallow fluted gouge shape the finial blank into a long slender taper leaving ⅛ inch at the tailstock end to cut off later.
- Plan and execute a design for the finial working carefully from the tailstock end toward the headstock.



Mount the blank at the base of the jaws



Round then taper the blank

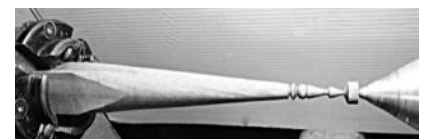

Shape finial from tailstock end

- Create a tenon at the base of the finial to match the hole drilled into which it is to be fitted. The tenon should be approximately $\frac{1}{4}$ inch in length. It is important to recheck the exact diameter of the hole with calipers before cutting the matching tenon.
- Undercut the tenon area to allow the finial to set snugly against the curved shape of the ornament body.

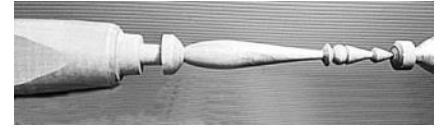

Add tenon and complete the tip

- Part off the finial in the center of the tenon leaving half of the tenon remaining.

- Using the remaining portion of the tenon may be used for a top finial if making a Christmas ornament. Under cut it to snugly fit the top portion of the ornament body.



Use 1/2 the tenon for the top finial

- Shape the opposite side into a small round shape, sand and part off.

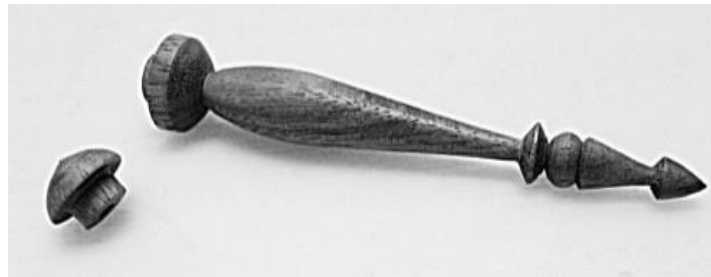

The completed set of finials

Other projects

Candle Stick or a Candle Stick Set

Objectives

- Learn to turn more complex shapes.
- Learn to turn from drawings.
- Transfer dimensional drawing information to a project through direct measurement transfer and “story sticks.”

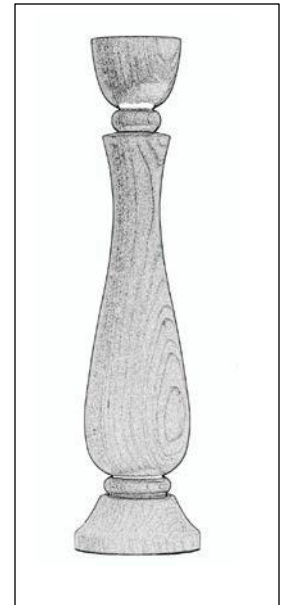

Materials required

One 3"x3"x 9" hardwood blank for the first candle stick. One 3"x3"x9" blank for each additional candle stick.

Discussion

The difficulty of this project is in making three objects match. This requires more careful planning and transfer of the dimensions and diameters before starting to turn the shape. Making a set of three related candle sticks also requires some creative decisions concerning how to increase or reduce the dimension by 10%. To get the best results don't skip making the drawings!

Activity

- Rough out a blank and transfer key transitions to its face. Transfer only the key dimensions. Be sure to start the project from the tailstock end of the wood.
- With your parting tool and a pair of calipers transfer the key diameters at the pencil lines added above.
- Start turning the shapes from the tailstock end working toward the headstock end.

If you are making the set:

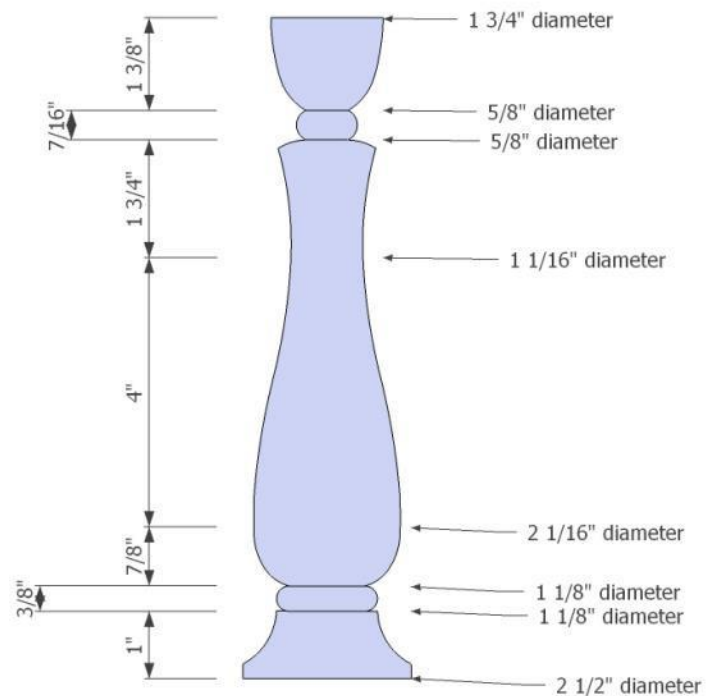

- Turn a second candle stick 10% smaller than the original by determining the new dimensions and creating an accurate scale drawing before starting.
- As with the first candle stick, transfer the dimensions and carefully turn it in the same manner. It will be important to assure that the shape pleasingly matches the first version.
- The third candle stick should be 10% larger than the original using the same processes.



Part one: Making the first candle stick

- Rough turn a blank between centers.
- Add a tenon and transfer the blank to a four-jaw chuck.
- Transfer dimensional information from the drawing.
- Turn the candle stick to match the drawing.
- Drill a candle taper recess in the top.
- Sand and part off.

Part two: Designing and turning your own candle stick set

- Create a new drawing using a sheet of ¼" grid graph paper.
- Make this drawing like the original model except 10 % smaller. Consider what proportions need to change and which need to remain the same.
- Add appropriate dimensions to allow you to transfer the drawing to the lathe.
- Turn your designed candle stick in the same manner as above.
- Repeat the activity by making another new drawing 10% larger than the original and repeating all the above